

think process!

WP Haton



CCR 59

Conical Rounder

WP BAKERYGROUP

think process!

CCR 59

Picture CCR 59 with oiling, infeed and discharge conveyor and discharge cone

SUITABLE FOR MANY COMMON DOUGH TYPES, SUCH AS WHEAT,
WHEAT / RYE, MULTIGRAIN AND WHOLE WHEAT DOUGHS.



BENEFITS

- Excellent round moulding results
- Perfect separation between dough pieces coming from the divider
- Minimum of dough crumbs
- Perfect transfer from dough pieces on the out-feed side
- The combination of cylindrical and conical cone gives an extra-long round moulding way, therefore this round moulder works also perfect as an end round moulder
- Adjustable tracks on infeed cylindrical part
- Dough pieces are turned half way round moulding process
- Wide weight range, caused by using different types of tracks

BASIC EXECUTION:

Without oiling

- Cast iron cylinder/cone, Teflon coated
- Aluminium tracks, in- and outside Teflon coated
- Cone with top bearing
- Frame steel, nickel plated
- Cover plates stainless steel, brushed
- Undercarriage nickel steel with 4 swivel castors with mounting pins
- With operation control panel

With oiling

- Cast iron cylinder/cone, Teflon coated
- Aluminium tracks, in- and outside Teflon coated
- Cone with top bearing
- Frame steel, nickel plated
- Cover plates stainless steel, brushed
- Undercarriage nickel steel with 4 swivel castors with mounting pins
- With operation control panel
- 7 oil spraying nozzles on cone
- Heating and blower

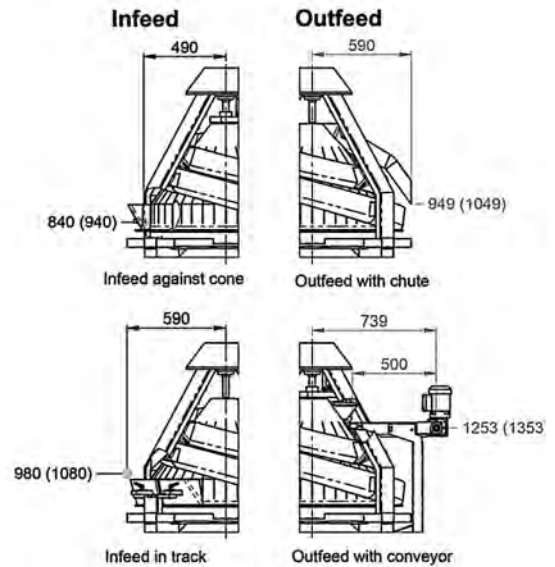
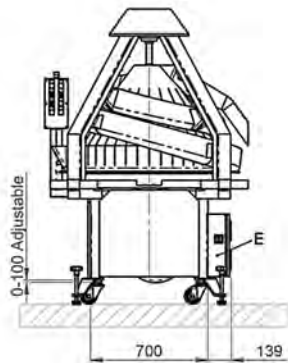
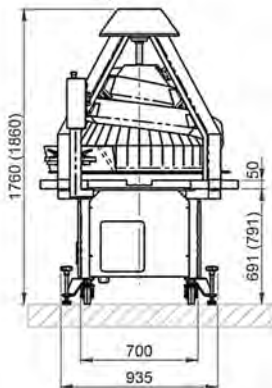
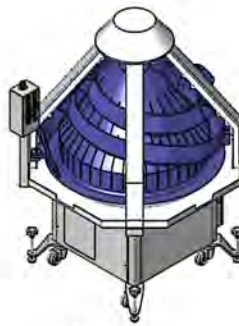
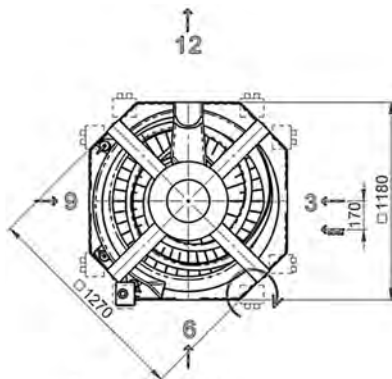

CCR 59

TYPE	WEIGHT RANGE	CAPACITY
KK	100 - 700 gr	up to 2500 pcs/h., E-motor 1,1 kW, 1400 rpm, n cone 27 rpm
KM	100 - 700 gr	
KG	200 - 1200 gr, including inserts	2500 up to 3600 pcs/h., E-motor 1,1 kW, 1400 rpm, n cone 39 rpm
GM	400 - 1600 gr	
GG	400 - 2000 gr, including inserts	3600 up to 5000 pcs/h., E-motor 1,1 kW, 1400 rpm, n cone 57 rpm

DIMENSIONS		WEIGHT	CONNECTED LOAD
Length	1200 mm	net 510 kg	230/400 V, 3 phase, 50 Hz + earth
Width	1200 mm	gross 580 kg	1,7 KVA (without heating)
Height	1760 mm	Shipping volume 2.8 m ³	4,5 KVA (with heating)

OPTIONS

CCR 59 without oiling

- Infeed conveyor, L=700, 950 or 1200 mm, reversible
- Discharge conveyor, cross, L=1200 mm, reversible
- Discharge conveyor, straight, with discharge cone
- Connection to central hot air blowing device (no pipes)
- Heating with fan
- Frequency inverter for variable cone speed
- Flour duster, mechanical
- Flour duster with independent drive and photocell for dough detection (only in combination with discharge conveyor)
- Water dripping device (in case of 2nd / final rounding)
- Customer specific Blue Box

CCR 59 with oiling

- Infeed conveyor, L=700, 950 or 1200 mm, reversible
- Discharge conveyor, cross, L=1200 mm, reversible
- Discharge conveyor, straight, with discharge cone
- Connection to central hot air blowing device (no pipes)
- Frequency inverter for variable cone speed
- Oiling on cone and discharge conveyor divider, 7 oil nozzles
- Oiling on cone and infeed conveyor rounder, 8 oil nozzles
- Oiling on cone, infeed conveyor rounder and discharge conveyor divider, 9 oil nozzles
- Dough piece oil signalisation
- Customer specific Blue Box

WP HATON BV

Industrieterrein 13 // 5981 NK Panningen // Netherlands // Phone +31 77307-1860 // Fax +31 77307-5148 // info@wp-haton.com // www.wp-haton.com