

DR Bun Divider Rounder serie



DR Robot

Hydraulically assisted divider rounder with interchangeable dividing disc

Daub Divider Rounders are most advanced machines of their type on the market today. There is a choice of five models and seven dividing discs, allowing a wide range of choices for each baker or bakery shop.

The state-of-the-art Daub semi-automatic and automatic machines treat the dough gently. Dough distribution takes place in a smooth movement with powerful rounding motion producing perfect round rolls.

The ability to prepare many different products throughout a working day lets you respond quickly to consumer demands. A wide variety of dividing discs enables producing seasonal products easily.

All Daub Divider Rounders are equipped with a unique easy forward-tilting system that lifts the dividing disc forward whereas many machines have a disc that opens sideways. Heavy cast-iron footing in combination with widely placed wheels and overhang guarantee extreme machine stability even during heavy rounding operation.



Unique easy forward-tilting system helps you clean the robust dividing assembly without effort, saving time every day.



Interchangeable dividing disc (within 5 minutes) offers increased flexibility, a work range of 16 - 340 gr. and tilts forward for easy cleaning.



Heavy counter-weight provides stable footing. No damper is required and the stability of the machine protects the floor and adjacent furniture, at the same time it is easily movable.



Anodized coated aluminium dividing disc and stainless steel knife require minimal flour for dividing and are hygienic in use.

DR Robot

Hydraulically assisted divider rounder with interchangeable dividing disc

- Powered dough dividing and rounding with easy weight adjustment and simple two-hand operation for extra safety
- Easily interchangeable dividing disc with maximum flexibility for work ranges from 16 to 340 gr.
- Unique easy forward-tilting system provides user-friendly, efficient and safe opening for cleaning
- Energy efficient with automatic motor switch only operating when machine is rounding
- Extremely stable, even during rounding, because of heavy cast iron foot counter-weight with overhang and widely placed wheels
- With cast iron footing on wheels extra stable and easy movable
- Stainless steel dividing knife
- Coated anodized aluminum dividing disc
- Stable, smooth and quiet in daily operation
- Easy cleaning with minimum maintenance required
- Three lightweight synthetic rounding plates included

Options

- Variable hydraulic pressure regulation
- Increased (fixed) rounding speed of 25%
- Marine execution with floor connection (instead of cast iron foot)
- Dampers (instead of cast iron foot)
- Transformer for 4 wire connections without N at 400 V
- UL safety and hygiene approvals
- Cooling ventilator in base frame
- Temperature controlled cooling ventilator
- Special colour

Power 1.3 kW, 3-phase, net weight: 345 kg
WxDxH 62 x 67 x 170 cm

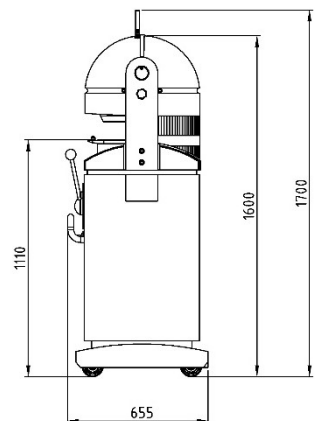
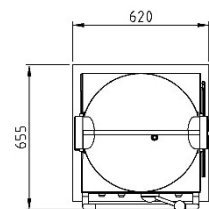
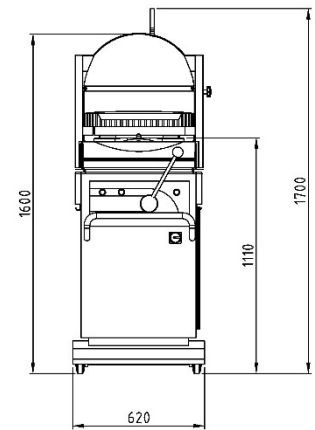

Voltage	Hz	Phase	Ampere	Wattage
400 - 460 V	50 - 60 Hz	3 phase / ground / neutral	6A	1.6 kW
200 - 270 V	50 - 60 Hz	3 phase / ground	9A	1.6 kW
400 - 460 V	50 - 60 Hz	3 phase / ground	6A	1.6 kW
208 V	60 Hz	3 phase / ground	9A	1.6 kW