

Varimixer

AR100

STRONG AND EFFECTIVE The powerful motors have the capacity to handle large quantities of heavy ingredients.

VARIABLE SPEED CONTROL The speed is variably controlled by a very rugged system of belts, rather than gears. This solution means that the mixer does not contain oil, thus avoiding the risk of oil spilling into the bowl.

DIGITAL TIMER operation time can be controlled or monitored via a digital timer. The machine stops at 00:00

MULTIPLE CAPACITIES IN ONE MACHINE
Bowls and tools are available for production of both 100, 60 and 40 liter.

REMOVABLE SAFETY GUARD The removable safety guard is made of stainless steel and is easy to attach and dishwasher safe. Protects against dust and splashing.

AUTOMATIC FIXATION The bowl is wheeled into place between the two bowl arms. Using the handle – or automatically by pressing a button – the bowl is raised, centered and locked in place in a single movement.

EASY BOWL HANDLING Choose between bowl truck for transport or an electric bowl lift, which handles transport to and from the machine and all bowl lifts. This also ensures good ergonomics during filling and emptying. Choose between several models.

WHITE OR STAINLESS STEEL An easy-to-clean design. The AR series is powder coated as standard and can be upgraded to a completely stainless steel frame.



VARIMIXER AR100 OPTIONS – MODELS



White, powder coated



Stainless steel



Marine version, stainless steel

OPTIONS – CONTROL PANEL



VL-1L – Manual speed regulation and automatic bowl lowering



VL-1S – Automatic speed regulation and automatic bowl lowering

OPTIONS – SAFETY GUARDS



Removable safety guard in stainless steel. CE-certified

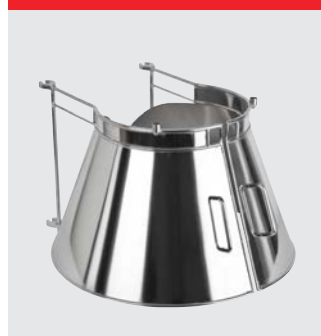

Removable splash guard in stainless steel. CE-certified

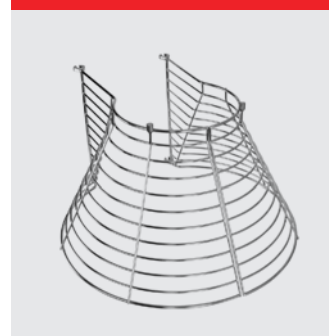

Removable safety guard in stainless steel. Not CE-certified

VARIMIXER AR100 STANDARD TOOLS – A-EQUIPMENT 100L



Whip, hook, beater and bowl 100 liter in stainless steel.

VARIMIXER AR100 STANDARD TOOLS – B-EQUIPMENT 100/60L AND C-EQUIPMENT 100/40L



Whip, hook, beater and bowl 100/60 liter in stainless steel and Whip, hook, beater and bowl 100/40 liter in stainless steel.

OPTION – TOOLS



Wing whip, stainless steel



Whip with 1 mm thicker wires, stainless steel



Whip with thinner wires, stainless steel



Whip with reinforcement



Beater, stainless steel

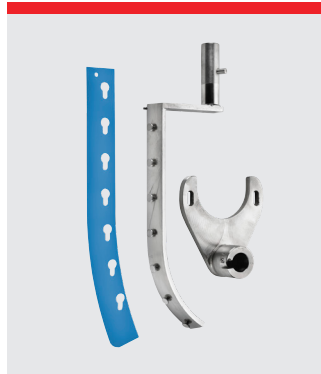

Automatic scraper, stainless steel. 100L, 100/60L, and 100/40L.



Powder mixer, stainless steel



Tool rack, 127 cm

EQUIPMENT



Bowl truck



Easylift 80-140



Maxilift Inox

VARIMIXER AR100 STANDARD

White powder coated
1 bowl 100 liter in stainless steel
1 beater in aluminium (food grade)
1 hook in stainless steel
1 whip with stainless steel wires
Removable safety guard in stainless steel – CE-certified
Digital timer and emergency stop
Voltage: 3 ph, 400V, 50 Hz with 0 and ground. 2.900 W

VARIMIXER AR100 STANDARD TECHNICAL DATA

Volume	100 l
Effect	2.900 W
Voltage*	400 V
Residual current devices (RCD):	
Industrial environment	PFI type A
Light industry/domestic	HPFI type A
Net weight	450 kg
Shipping gross weight	495 kg
H x W x L (Shipping dimensions)	1840 x 860 x 1350 mm
H x W x L (Product dimensions)	1594 x 684 x 1175 mm
HS Code	84381010
Vol. m ³	2.06 m ³
Ldm	0.50
Variable speed	47 – 257 RPM
Phases	3 ph
IP code	IP32

*Other voltage power supply are available upon request in the range of 100 to 480 V. All standard and marine mixers are available in 50 and 60 Hz.

VARIMIXER AR100 MARINE VERSION - IP CODE: IP44

Stainless steel execution, water cover at air ventilation, slotted free screws, full welded stainless steel knees, gasket at the rear plate, gasket at front panel and top cover. Complies with USPHS.

Voltage: 3 ph, 440V, 50-60 Hz with 0 and ground. 2.900 W
3 ph, 480V, 50-60 Hz with 0 and ground. 2.900 W

DIMENSIONS

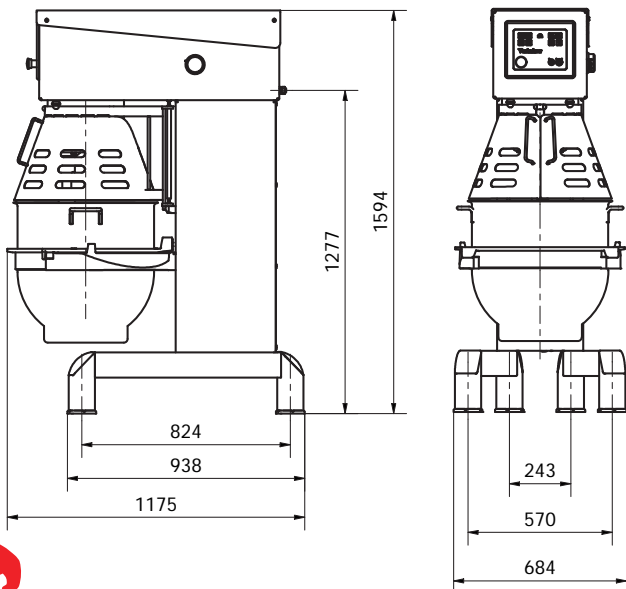

Varimixer

Varimixer A/S
Elementfabrikken 9
DK-2605 Brøndby
P: +45 4344 2288
E: info@varimixer.com
www.varimixer.com

CAPACITIES

Tools	Product		Special attention
Whip	Egg Whites	5 l	
	Whipped cream	25 l	
	Buttercream frosting	45 l	+ □
	Layer Cake Sponges	26 kg	
	Mayonnaise	40 l	+
Beater	Mashed potatoes	54 kg	+
	Cakes	55 kg	
	Icing, Fondant	40 kg	+
	Herb Butter	35 kg	+ □
	Meatball / Vegan meatball mix	60 kg	+
Hook	Pasta, noodles (50%AR)	45 kg	●
	Dough, wheat (50%AR)	50 kg	●
	Dough, wheat (55%AR)	58 kg	●
	Dough, wheat (60%AR)	65 kg	●
	Dough, whole wheat (70%AR)	65 kg	
	Dough, rye bread	80 kg	+
	Dough, sourdough bread	65 kg	
	Dough, gluten free	47 kg	

The capacity chart shows the maximum capacity for the specific machine. The testing has been conducted with standard equipment. Therefore, the use of special tools, can result in a different outcome. Always start the machine at the lowest speed. Increase the speed subsequently, taking the product being mixed into account.

Symbols explainer - Recommended actions:

- + = Apply scraper, for the best and most efficient result
- = Always make sure the ingredients are room temperature/soft. If not, this can damage the tools.
- = Recommended to work on low speed.
- = Recommended not to go above medium speed.
- AR = Absorption Ratio (moisture in % of dry matter)

CERTIFICATIONS

