

Varimixer

AR200

CONTROL PANEL Choose between variable speed control, fixed speeds or up to 24 programs with their own processes. All operations are controlled from the intuitive, angled touch panel control panel. The panel is easy to clean and is dustproof and waterproof.

REMOVABLE SAFETY GUARD The removable safety guard is made of stainless steel and is easy to attach and dishwasher safe. Protects against dust and splashing.

AUTOMATIC FIXATION The bowl is wheeled into place between the two bowl arms. Using the handle – or automatically by pressing a button – the bowl is lowered or raised and locked in place in a single movement.

EASY BOWL HANDLING Choose between bowl truck for transport or an electric bowl lift, which handles transport to and from the machine and all bowl lifts. This also ensures good ergonomics during filling and emptying. Choose between several models.

STRONG AND EFFECTIVE The powerful motors have the capacity to handle large quantities of heavy ingredients.

HYGIENIC AND EASY TO CLEAN All surfaces and accessories are made of stainless steel, and the design ensures the best possible hygiene and very easy cleaning. Varimixer AR200 can be washed in accordance with the IP53 standard, and can be upgraded to either a marine version or IP54 cleaning, with a waterproof stainless steel mixer head.



STAINLESS STEEL An easy-to-clean design. The AR200 comes as standard with completely stainless steel frame.

VARIMIXER AR200 OPTIONS – MODELS



Stainless steel



Marine version, stainless steel

CONTROL PANEL



VL-5 – Automatic speed regulation and manual bowl lowering

OPTIONS – IP54



Waterproof planetary head, stainless steel, IP54



Air ventilation - Double layer protected, stainless steel, IP54

OPTIONS – SAFETY GUARDS

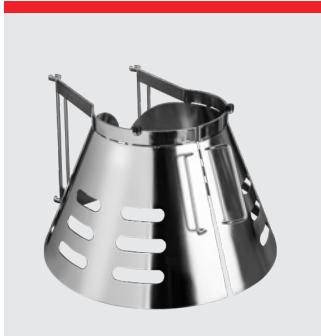

Removable safety guard in stainless steel. CE-certified

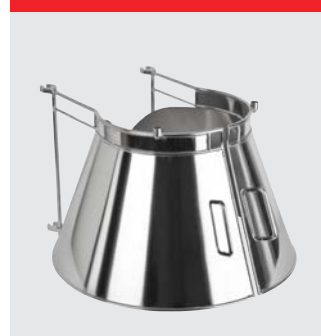

Removable splash guard in stainless steel. CE-certified

VARIMIXER AR200 STANDARD TOOLS – A-EQUIPMENT 200L



Double center reinforced whip with double pin in stainless steel and bowl 200 liter in stainless steel.

OPTION – TOOLS



Whip with double pin, stainless steel



Wing whip with double pin, stainless steel



Beater with double pin, stainless steel

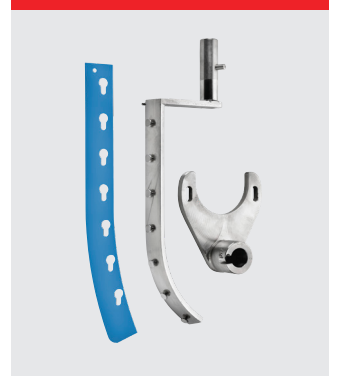

Automatic scraper, stainless steel.



Bowl with bottom draining pipe, stainless steel



Tool rack, 127 cm

EQUIPMENT – TRANSPORTION



Bowl truck



Megalift Inox



Wheels for bowl

VARIMIXER AR200 STANDARD

Stainless steel
1 bowl 200 liter in stainless steel
1 double center reinforced whip with double pin stainless steel
Removable safety guard in stainless steel – CE-certified
Digital timer and emergency stop
Voltage: 3 ph, 400V, 50 Hz with ground. 7.500 W

VARIMIXER AR200 STANDARD TECHNICAL DATA

Volume	200 l
Effect	7.500 W
Voltage*	400 V
Residual current devices (RCD): Industrial environment Light industry/domestic	HPFI type A-SI or PFI type B HPFI type A-SI
Net weight	600 kg
Shipping gross weight	660 kg
H x W x L (Shipping dimensions)	2305 x 1000 x 1450 mm
H x W x L (Product dimensions)	2057 x 863 x 1373 mm
HS Code	84381010
Vol. m ³	3.34 m ³
Ldm	0.60
Variable speed	47 – 259 RPM
Phases	3 ph
IP code	IP53
IP code upgrade	IP54

*Other voltage power supply are available upon request in the range of 200 to 480 V. All standard and marine mixers are available in 50 and 60 Hz.

VARIMIXER AR200 MARINE VERSION - IP CODE: IP54

Stainless steel execution, water cover at air ventilation, slotted free screws, full welded stainless steel knees, gasket at the rear plate, gasket at front panel and top cover. Complies with USPHS.

Voltage: 3 ph, 440V, 50-60 Hz with 0 and ground. 7.500 W
3 ph, 480V, 50-60 Hz with 0 and ground. 7.500 W

DIMENSIONS

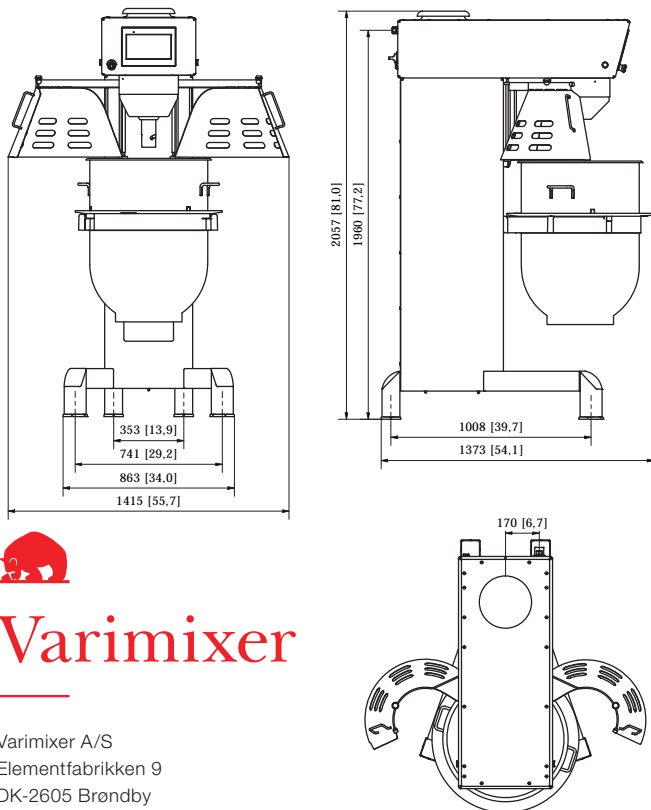

Varimixer

Varimixer A/S
Elementfabrikken 9
DK-2605 Brøndby
P: +45 4344 2288
E: info@varimixer.com
www.varimixer.com

CAPACITIES

Tools	Product		Special attention
Whip	Egg Whites	10 l	
	Whipped cream	50 l	
	Buttercream frosting	90 l	+ □
	Layer Cake Sponges	- kg	
	Mayonnaise	- l	
Beater	Mashed potatoes	107 kg	+
	Cakes	110 kg	
	Icing, Fondant	80 kg	+
	Herb Butter	70 kg	+ □
	Meatball / Vegan meatball mix	120 kg	+

The capacity chart shows the maximum capacity for the specific machine. The testing has been conducted with standard equipment. Therefore, the use of special tools, can result in a different outcome. Always start the machine at the lowest speed. Increase the speed subsequently, taking the product being mixed into account.

Symbols explainer - Recommended actions:

- + = Apply scraper, for the best and most efficient result
- = Always make sure the ingredients are room temperature/soft. If not, this can damage the tools.
- = Recommended to work on low speed.
- = Recommended not to go above medium speed.
- AR = Absorption Ratio (moisture in % of dry matter)

CERTIFICATIONS

