

Varimixer

AR40

MULTIPLE CAPACITIES IN ONE MACHINE

Bowls and tools for production at half volume are available for AR40.

DIGITAL TIMER

Mixing time can be adjusted and monitored on the digital timer. The mixer will stop at 00:00 and signal a beep to notify the operator.

MEAT MINCER AND VEGETABLE CUTTER

Models from AR30 to AR80 can be ordered with an attachment drive, to expand the mixer's potential applications.

MAGNETIC SAFETY GUARD

The front and rear of the guard can easily be removed and washed in a dishwasher. This makes the cleaning of the machine much easier and ensures optimum hygiene.

AUTOMATIC FIXATION

The bowl is wheeled into place between the two bowl arms. Using the handle – or automatically by pressing a button – the bowl is raised, centered and locked in place in a single movement.

EASY BOWL HANDLING

Choose between bowl truck for transport or an electric bowl lift, which handles transport to and from the machine. This also ensures good ergonomics during filling and emptying. Choose between several models.

WHITE OR STAINLESS STEEL

An easy-to-clean design. The AR series is powder coated as standard and can be upgraded to a completely stainless steel frame.

STAINLESS STEEL LEGS

As extra protection against rust, the vertical part of the legs are always made of stainless steel.

STRONG AND EFFECTIVE

The powerful motors have the capacity to handle large quantities of heavy ingredients.

VARIABLE SPEED CONTROL

The speed is variably controlled by a very rugged system of belts, rather than gears. This solution means that the mixer does not contain oil, thus avoiding the risk of oil spilling into the bowl.



PIZZA SPECIAL

AR40 and AR60 are available in a special pizza version with an extra powerful motor that can easily handle 32 and 46 kg pizza dough, respectively, with 50 per cent dry matter.

VARIMIXER AR40 OPTIONS – MODELS



White, powder coated



Stainless steel



Pizza version, white, powder coated



Marine version, stainless steel

OPTIONS – CONTROL PANEL



VL-1 – Manual speed regulation and manual bowl lowering



VL-1S – Automatic speed regulation and automatic bowl lowering

OPTION – SAFETY GUARD WITH GRID



Stainless steel grid guard.
Not CE-certified

OPTIONS – ATTACHMENT DRIVE



Attachment drive for meat mincer and vegetable cutter



Meat mincer, 82 mm



Vegetable cutter GR20

VARIMIXER AR40 STANDARD TOOLS – A-EQUIPMENT 40L



Whip, hook, beater and bowl 40 liter in stainless steel.

VARIMIXER AR40 STANDARD TOOLS – B-EQUIPMENT 40/20L



Whip, hook, beater and bowl 40/20 liter in stainless steel.

OPTION – TOOLS



Wing whip, stainless steel



Automatic scraper, stainless steel. 40L and 40/20L.



Powder mixer, stainless steel



Tool rack, 91 cm

EQUIPMENT



Bowl truck



Easylift 30-60



Multilift 30-60



Flexlift Inox

VARIMIXER AR40 STANDARD

White powder coated
1 bowl 40 liter in stainless steel
1 beater in stainless steel
1 hook in stainless steel
1 whip with stainless steel wires
Magnetic removable safety guard – CE-certified
Digital timer and emergency stop
Voltage: 3 ph, 400V, 50 Hz with 0 and ground. 1.100 W

VARIMIXER AR40 STANDARD TECHNICAL DATA

Volume	40 l
Effect	1.100 W
Voltage*	400 V
Residual current devices (RCD):	
Industrial environment	PFI type A
Light industry/domestic	HPFI type A
Net weight	175 kg
Shipping gross weight	210 kg
H x W x L (Shipping dimensions)	1430 x 670 x 1100 mm
H x W x L (Product dimensions)	1209 x 557 x 952 mm
HS Code	84381010
Vol. m ³	1.06 m ³
Ldm	0.40
Variable speed	53 - 294 RPM
Phases	3 ph
IP code	IP32

*Other voltage power supply are available upon request in the range of 100 to 480 V. All standard and marine mixers are available in 50 and 60 Hz.

VARIMIXER AR40 MARINE VERSION - IP CODE: IP44

Stainless steel execution, water cover at air ventilation, slotted free screws, full welded stainless steel knees, gasket at the rear plate, gasket at front panel and top cover. Complies with USPHS.

Voltage: 3 ph, 440V, 50-60 Hz with 0 and ground. 1.100 W
3 ph, 480V, 50-60 Hz with 0 and ground. 1.100 W

CAPACITIES

AR40 AR40P

Tools	Product	AR40	AR40P	Special attention
Whip	Egg Whites	2	2 l	
	Whipped cream	8	8 l	
	Buttercream frosting	16	16 l	+ □
	Layer Cake Sponges	-	- kg	
	Mayonnaise	-	- l	
Beater	Mashed potatoes	21	21 kg	+
	Cakes	20	20 kg	
	Icing, Fondant	16	16 kg	+
	Herb Butter	12	12 kg	+ □
Hook	Meatball / Vegan meatball mix	24	24 kg	+
	Pasta, noodles (50%AR)	16	20 kg	●
	Dough, wheat (50%AR)	20	28 kg	●
	Dough, wheat (55%AR)	23	28 kg	●
	Dough, wheat (60%AR)	26	28 kg	●
	Dough, whole wheat (70%AR)	24	28 kg	
	Dough, rye bread	24	24 kg	+
	Dough, sourdough bread	24	24 kg	
	Dough, gluten free	19	19 kg	

The capacity chart shows the maximum capacity for the specific machine. The testing has been conducted with standard equipment. Therefore, the use of special tools, can result in a different outcome. Always start the machine at the lowest speed. Increase the speed subsequently, taking the product being mixed into account.

Symbols explainer - Recommended actions:

- + = Apply scraper, for the best and most efficient result
 - = Always make sure the ingredients are room temperature/soft. If not, this can damage the tools.
 - = Recommended to work on low speed.
 - = Recommended not to go above medium speed.
- AR = Absorption Ratio (moisture in % of dry matter)

CERTIFICATIONS



DIMENSIONS

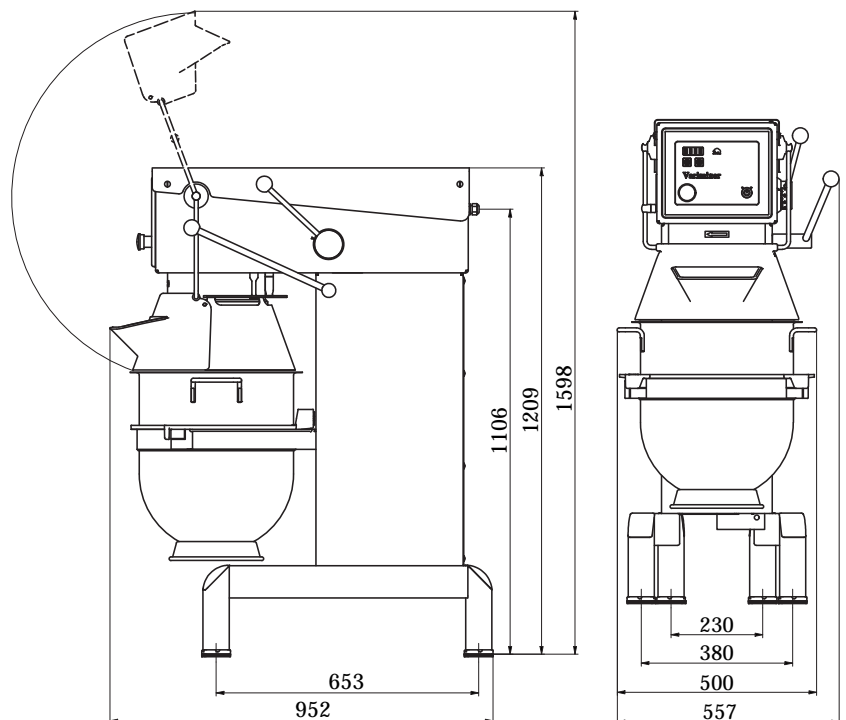

Varimixer

Varimixer A/S
Elementfabrikken 9
DK-2605 Brøndby
P: +45 4344 2288
E: info@varimixer.com
www.varimixer.com